

## Stainless Steel Single Point Load Cell

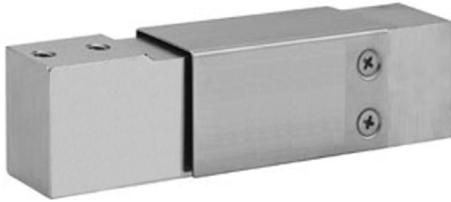

### FEATURES

- Capacities 15 - 150kg
- Stainless steel construction
- Single point 400 x 400mm platform
- IP65 protection
- Available with UNC threads only

### OPTIONAL FEATURES

- EEx ia IIC T4 hazardous area approval
- FM approval available

### DESCRIPTION

Model 1140 is a low profile single point load cell designed for direct mounting of low cost weighing platforms.

The small physical size, combined with high accuracy and low cost, makes this load cell ideally suited for low profile bench and counting scales. For wash-down protection an optional IP65 encapsulation protection is available.

Constructed from stainless steel this high accuracy load cell is approved to Factory

Mutual and other stringent approval standards.

The two additional sense wires feed back the voltage reaching the load cell. Complete compensation of changes in lead resistance due to temperature change and/or cable extension, is achieved by feeding this voltage into the appropriate electronics.

### APPLICATIONS

- Harsh environment small platforms
- Harsh environment check weighing

### OUTLINE DIMENSIONS in mm

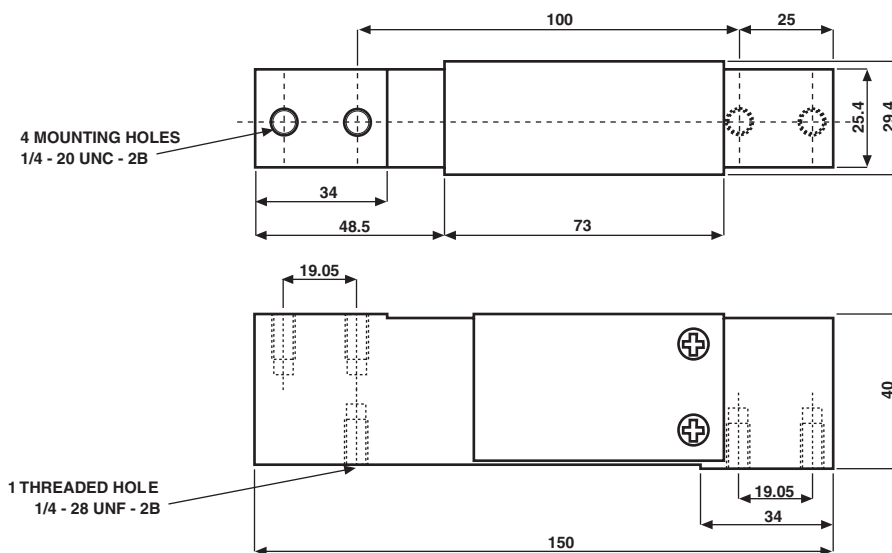

**SPECIFICATIONS**

PARAMETER	VALUE	UNIT
Rated capacity-R.C. ( $E_{max}$ )	15, 20, 30, 50, 75, 100, 150	kg
NTEP/OIML Accuracy class	<b>Non-Approved</b>	
Maximum no. of intervals (n)	3000	
Rated output-R.O.	2.0	mV/V
Rated output tolerance	0.2	±mV/V
Zero balance	0.2	±mV/V
Zero Return, 30 min.	0.0170	±% of applied load
Total Error (per OIML R60)	0.0200	±% of rated output
Temperature effect on zero	0.004	±% of rated output/°C
Temperature effect on output	0.0010	±% of load/°C
Eccentric loading error	0.0074	±% of rated load/cm
Temperature range, compensated	-10 to +40	°C
Temperature range, safe	-20 to +70	°C
Maximum safe central overload	150	% of R.C.
Ultimate central overload	300	% of R.C.
Excitation, recommended	10	Vdc or Vac rms
Excitation, maximum	15	Vdc or Vac rms
Input impedance	385±15	Ohms
Output impedance	350±3	Ohms
Insulation resistance	>2000	Mega-Ohms
Cable length	1.0	m
Cable type	6 wire, PVC, single floating screen	Standard
Construction	Stainless steel	
Environmental protection	IP65*	
Platform size (max)	400 x 400	mm
Recommended torque	Up to 30kg: 7.0 50kg & up: 10.0	N*m

\* IP67 available on request

WIRING SCHEMATIC DIAGRAM

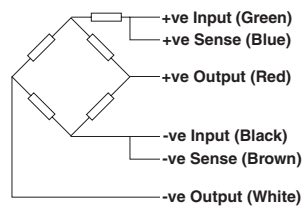

## Disclaimer

All product specifications and data are subject to change without notice.

Vishay Precision Group, Inc., its affiliates, agents, and employees, and all persons acting on its or their behalf (collectively, "Vishay Precision Group"), disclaim any and all liability for any errors, inaccuracies or incompleteness contained herein or in any other disclosure relating to any product.

Vishay Precision Group disclaims any and all liability arising out of the use or application of any product described herein or of any information provided herein to the maximum extent permitted by law. The product specifications do not expand or otherwise modify Vishay Precision Group's terms and conditions of purchase, including but not limited to the warranty expressed therein, which apply to these products.

No license, express or implied, by estoppel or otherwise, to any intellectual property rights is granted by this document or by any conduct of Vishay Precision Group.

The products shown herein are not designed for use in medical, life-saving, or life-sustaining applications unless otherwise expressly indicated. Customers using or selling Vishay Precision Group products not expressly indicated for use in such applications do so entirely at their own risk and agree to fully indemnify Vishay Precision Group for any damages arising or resulting from such use or sale. Please contact authorized Vishay Precision Group personnel to obtain written terms and conditions regarding products designed for such applications.

Product names and markings noted herein may be trademarks of their respective owners.